

LS40 Motor Installation Instructions

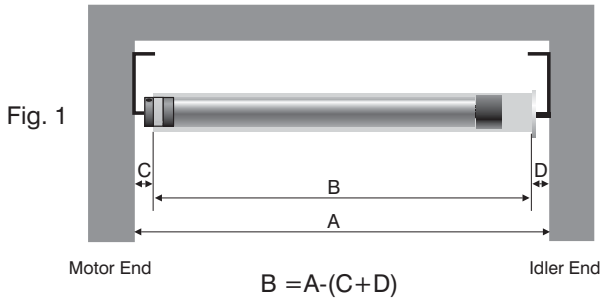

For All Round Tubes

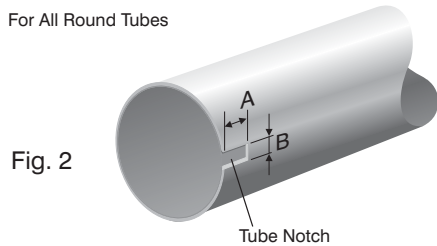

Notch: LS40 Length = $\frac{A}{.335 / 8.5}$ in./mm Width = $\frac{B}{.236 / 6}$ in./mm

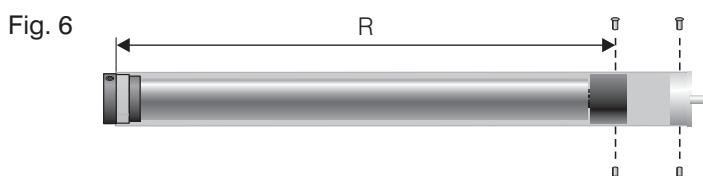
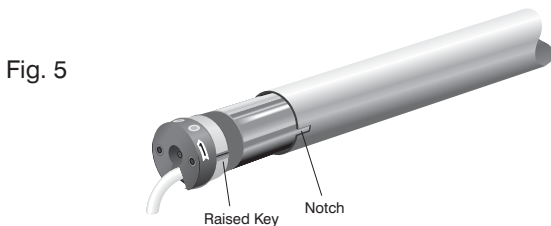
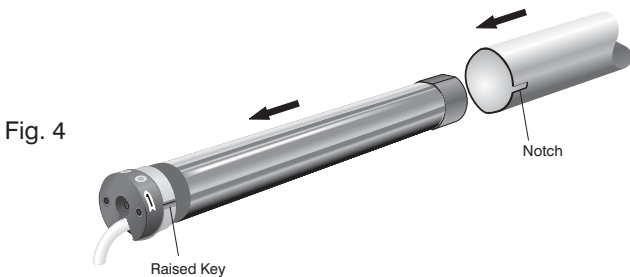
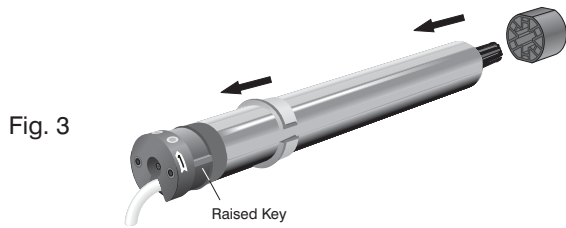

1. TUBE PREPARATION

- Cut the tube to the required length (B), taking into account the width of the installation (A), the motor end clearance, which includes motor head and motor bracket thickness (C), and the idler end clearance, which includes idler end cap and idler bracket thickness (D). (See Fig. 1)
- USE FORMULA TO DETERMINE MEASUREMENTS.
- Remove all burrs from the ends of the tube and ensure that the inside of the tube is clean.
- For all round tubes, notch the tube on the motor end to the dimensions A & B. (See Fig. 2)

2. PREPARING THE TUBULAR MOTOR

- Carefully pull open the one piece crown in order to fit over the body of the motor. Slide the opening of the crown wheel over the recessed part of the motor's limit switch unit and close it over the Raised Key. (See Fig. 3)
- Fit the drive wheel onto the output shaft of the motor.

3. FITTING THE MOTOR INTO THE TUBE

For round tubes: Measure the drilling length R according to the motor type listed in the table below. Fit the motor into the tube ensuring that the notch at the end of the tube slides over the raised key on the crown wheel. (See Fig. 4 & 5) Secure the drive wheel to the tube using four 5/32 steel pop rivets or four #10 screws. Fit the end plug into the other side of the tube and secure it with three steel pop rivets. Use only fasteners with steel grades SAE 5 or higher. Metric fasteners must be grade 8.8 or higher. (See Fig. 6)

4. LIMIT SWITCH SETTING

SOMFY strongly recommends using a Tester Cable (T.C.) Cat. No. 6020086 to set the motor limits, and to ensure the system is operating correctly before the final electrical connection is made. Refer to Step 6 "Trouble Shooting Guide" for any problems encountered.

Two positions have to be set: the UP & DOWN positions, this is where end product will stop automatically.

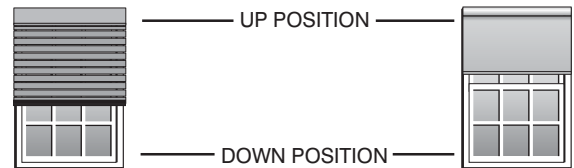

LS40

MOTOR TYPE	R in. / mm
401F1	16.6/421
404R2	16.6/421
404S2	16.6/421
409R2	16.6/421
412R2	16.6/421

Adjustment of Upper and Lower Positions for the LS40

- 1 Ensure the tester cable switch is in the center "OFF" position, and connect T.C. to motor leads by matching color codes.
- 2 Identify the UP recessed limit screw by finding the arrow on the motor head which points in the direction that retracts (rolls up) the system.
- 3 Turn the power on to ensure that the switch is operating properly (UP-raises, DOWN-lowers). If not, turn the power off and simply reverse the black and red motor leads.
- 4 Flip the tester cable switch in the UP direction. If the system stops before its UP limit, turn the UP screw to "+" until necessary. If the system does not stop at its UP limit, flip the tester cable switch in the DOWN direction and turn the UP screw to "-". Repeat this until the correct setting is achieved.
- 5 Flip the tester cable switch in the DOWN direction. If the system stops before its DOWN limit, turn the DOWN limit screw to "+" . If not, flip the tester cable switch in the UP direction and turn the DOWN limit screw to "-". Repeat this until the correct setting is achieved.

NOTE: 7 turns of Hex Screws equals 1 turn of roller tube.

NOTE: Recessed thumbscrews can accommodate a flat head screwdriver (4mm wide max.), SOMFY's Allen wrench (Cat. No. 6500258) or Flexible limit switch adjuster (Cat. No. 6500091).

NOTE: Tubular motors are not continuously rated. They have a built-in thermal overload device which limits their operation to approximately 5 minutes. A maximum 15 minute cool down period is required if the motor reaches thermal overload.

5. WIRING/INSTALLATION RECOMMENDATIONS

- A. All wiring must conform to NEC (National Electrical Code) and local codes
- B. Do not wire two or more motors to one SPDT (single pole double throw switch-NO PARALLEL WIRING).
- C. Do not use light switches to control SOMFY motors.
- D. Do not wire two or more switches to one motor, without using SOMFY's multi switch command. Cat. No. 6300427.

NOTE: SOMFY motors conform to IP44 requirements and as such must be protected against direct weather elements such as rain, sleet,...etc.

6. TROUBLESHOOTING GUIDE

SYSTEM DOES NOT RESPOND

- Is the power supply switched on - check any fuses in the system?
- Is control switch wired correctly? Refer to instructions.
- Are limit switches set properly? Review limit switch settings.
- The thermal protective device may have shut the motor off. Wait for the motor to cool down.
- Check the wiring between the motor & the switch.
- Disconnect the switch & test the motor with a tester cable.

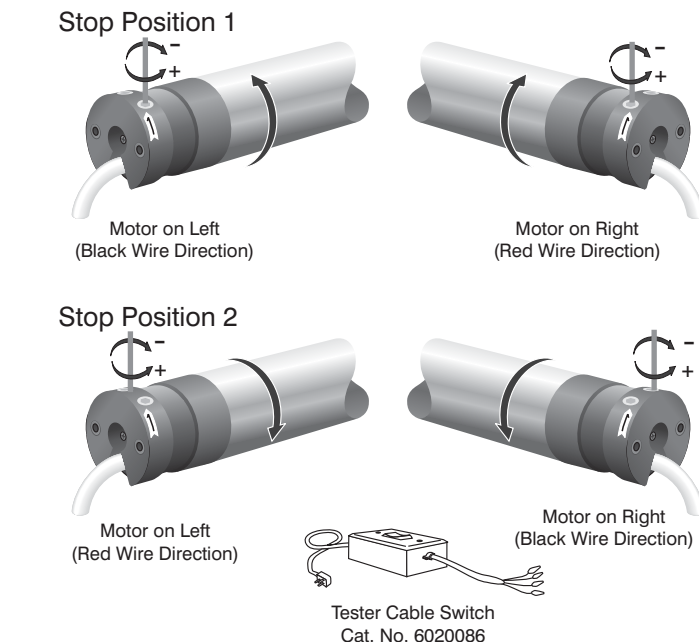

****** The motor cable should not act as a direct conduit for the water to enter the head of the motor (form drip loops).

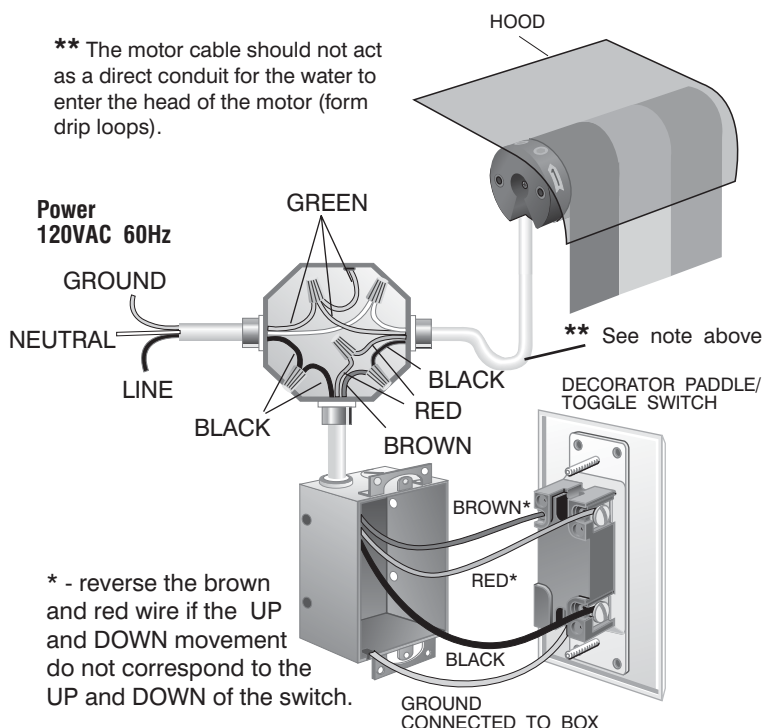

* - reverse the brown and red wire if the UP and DOWN movement do not correspond to the UP and DOWN of the switch.

THE SYSTEM IS NOT STOPPING

- Are limit switches set properly? Review limit switch settings.
- Is the limit switch crown wheel being driven by the tube (has tube profile been properly notched)?
- Is motor drive wheel securely fastened to the tube?

NOTE: if the motor is tested outside the tube, the crown wheel has to be manually turned in order to stop the rotation of the output shaft.

SOMFY reserves the right to void the motor warranty if the wiring recommendations are not followed.